

READ ME FIRST!!!



**SPEED AND SCIENCE Billet Aluminum Rocker
Boxes for 1966-1984 Harley Davidson®
"SHOVELHEAD" engines, P/N: OEM_SH_RB_001**

8190 River Road
Delta, BC V4G 1B5, CANADA
T: 778-727-0866
www.speedandscience.com
sales@speedandscience.com

<i>Revisions:</i>	<i>Description:</i>	<i>DATE:</i>
02	Pictures updated (Rocker Arm)	March 15 2023

DISCLAIMER:

SPEED AND SCIENCE (SNS) parts are designed and intended for closed course applications only. Our products must be installed by a mechanic experienced in American V-Twin engines and used by an experienced rider. Installation of SNS parts may affect or even void any other warranties if such apply to your motorcycle. Additionally, such installation may violate some federal, provincial, state and local laws, rules and ordinances. Always check federal, provincial, state and local laws prior to modifying your motorcycle. It is the sole and exclusive responsibility of the user to determine whether the product is correct for his/her use. The user shall assume all legal risks, liabilities, duties and obligations associated therewith.

Trademark Disclaimer: *The words Harley-Davidson®, H-D®, Sportster®, Evolution® TwinCam® and all OEM part numbers and model designations are registered trademarks of H-D Michigan, LLC, and are used for reference only. Speed And Science is not associated with Harley-Davidson, Inc.*

*****Not EPA Compliant, please check with your local Motor Vehicle Office for rules and regulations*****

INSTALLATION AND OPERATION SAFETY:

It is your responsibility to read and follow these instructions thoroughly and carefully prior to attempting any work on your motorcycle. Make sure you understand all procedures completely. Contact SNS with any questions you may have regarding an installation and/or operation of any SNS product. Please make safety your priority.

- *Motorcycle fuel is extremely flammable and explosive media, also toxic when breathed/ingested. Work only in well ventilated room equipped with appropriate fire extinguishing gear. Avoid any open flames or sparks, do not smoke.*

- Exhaust fumes are toxic and must not be breathed. Run your motorcycle in a well ventilated area; also never stay in the way of the exhaust fumes.
- Motorcycle engine and certain accessories do get very hot after even a very short run. Always allow those to cool down before attempting any work.
- Always disconnect the motorcycle battery prior to attempting any work. Secure the battery terminals and cables to prevent any accidental re-connect and/or short-circuit.
- Consult an appropriate service manual[s] for other procedures that may be needed in order to facilitate an installation of the SNS part[s].
- Never work on, or operate your motorcycle while under influence of alcohol or drugs. Fatigue will affect your proper judgement ability also. Please keep yourself and others safe.
- Always check federal, provincial, state and local laws prior to modifying your motorcycle.

WARRANTY:

- All SNS parts are guaranteed to the original purchaser to be free of manufacturing defects in materials and workmanship for a period of 12 (twelve) months from the date of purchase.
- SNS must be notified immediately about any of our products that do not conform to the above. After a case review, an RMA number will be issued to the purchaser and the product[s] must be returned pre-paid to us within the 12 month warranty period or 10 business days thereafter and will be replaced or repaired at SNS's option.
- The returning parts must be packaged properly as to prevent any shipping damage.
- The shipment must include a copy of the original purchase receipt, Invoice, etc., also a detailed note outlining the nature of the problem.
- Upon positive case review, a repair, replacement or refund will be granted.
- The purchaser is solely responsible for proper installation of any SNS product, using proper tools and techniques as per commonly used shop procedures and manuals.
- SNS shall not be responsible for any part defects being result of improper installation, improper/lack of maintenance, improper use and operation, or any other abnormal misuse or mistreatment of said part.
- SNS shall be not liable for any consequential or incidental damages resulting from the failure of a SNS part, the breach of any warranties (written or implied), the failure to deliver, etc.

INSTALLATION GUIDANCE AND RECOMMENDATIONS:

***** WARNING!!! *****

- **Anytime during assembly and/or while checking for clearances, under NO CIRCUMSTANCES the engine should be forced to rotate if ANY RESISTANCE is observed. Doing so, or failing to provide correct clearances may cause an engine damage and will not be covered by warranty.**
- **In process of design we have upgraded the internal shafts to the EVO style, however we have added internal oil passages. Engine damage will occur if standard EVO shafts are installed!!!**
- **Upper and Lower machined halves are not interchangeable between Front and Rear sets!!!**
- **While re-installing the assembled components into the frame, check for potential interference. We have incorporated clearances into the design (especially Rear Box), but due to the variety of motorcycle frames being used (OEM or Custom) the installer may be required to perform some minor modifications as needed. Remove the least amount of material possible and only from the interfering area!!!**

1. SNS Shovelhead Billet Rocker Box set has been designed to fit all 1966-1984 Harley Davidson "Shovelhead" models with OEM oil supply system. They will fit over both OEM cast heads as well as the billet SNS heads (recommended). An utmost care has been exercised to ensure a direct fit and function, however due to the large variety of models manufactured and/or extensive customization afterwards, the installer may be required to perform some minor modifications as needed.
2. SNS Billet Rocker Boxes provide superior fit and function vs. castings. They have been designed with extra clearances, however due to a wide variety of possible combinations the builder must make sure to retain a clearance of min. .060" between moving parts and the body throughout the entire moving range. On a rare occasion, a careful material removal from the inside of the rocker box (or the rocker itself, see pic. below) will be necessary. Remove the least amount of material possible and only from the interfering area.
3. The Rocker Boxes are designed for OEM shape rockers (standard or roller type, not included in the kit). The builder must ensure the correct fit. Radial play must be no more than .001", otherwise the brass bushings inside the rockers must be replaced as per factory procedure. The service manual states axial play as .004'-.025". We recommend .010"-.020". If need be, an end of the rocker (either one) must be carefully machined in order to achieve the min. clearance. In any case no shimming is allowed nor necessary.
4. With the exception of the 5/16UNC bolts (4), 1/4-UNF set screws (4), rocker shafts (4), dowel pins (4), end caps (4) and internal seals (8), the SNS Rocker Box sets have no other hardware provided. The purchaser is responsible for procuring and proper installation thereof as per commonly used shop procedures and manuals.
5. Installation of Rocker Boxes should be done as per service manual. OEM shape gaskets must be used between the Rocker Boxes and the heads. The sets are shipped with internal seals (orings) that should not be removed unnecessarily. For spare seals, etc. please see the Optional For Purchase section below.

ASSEMBLY PROCEDURE (also refer to the pictures below):

- a) Unscrew the two 5/16 Bolts (C) and gently separate the Upper and Lower parts of the Box. Keep Front and Rear sets separately. Small Dowel Pins inside - do not misplace!
- b) Place the upper (larger) box upside-down on a bench (use clean rag underneath to protect the finish).
- c) Unscrew/remove the End Caps (A) (orings inside – do not misplace!) and take note of the approx. shaft position (depth) inside the hole.
- d) Unscrew/remove the small 1/4UNF (D) set screws.
- e) Pull out the shafts. A gentle application of compressed air into hole B will do the trick.
- f) Place the rocker arm (Intake / Exhaust rockers are different, please pay attention!) inside the upper box.
- g) Use small amount of an assembly lube on the shaft. Carefully slide the shaft into the reamed hole, larger chamfer forward (shaft's center hole and slot/dimple towards the outside). Keep the slot/dimple facing up (important).
- h) Slightly lift and wiggle the rocker arm around while gently pushing the shaft forward as to align them both. Once the shaft "finds" the rocker, push it further forward until inserted into the far hole, but stop before it hits the bottom!!
- i) The shaft is in the correct position once the slot/dimple lines up with the 1/4UNF hole.
- j) Secure the shaft with the 1/4UNF set screw (D) – use light-duty thread compound. Do NOT overtighten!!
- k) Before replacing the End Cap, make sure the oring is seated fully in cap's groove, also the end surfaces (both cap and bottom of the hole) are perfectly clean and dry. Use anti-seize compound on thread. Screw the cap very carefully in (do not cross-thread!!) and torque to 25 ft/lbs.
- l) Repeat the above procedure for all remaining rocker arm locations.
- m) Clean the mating surfaces of Upper and Lower parts. Make sure, the long seals in Lower part are seated fully in their grooves and Dowel Pins (2 per box) are in place.
- n) Carefully put both halves together making sure the FRONT and REAR sets match up (see pictures below). Pay attention to the dowel pin alignment – both halves should snap together very easily – under any circumstances do NOT force the parts together!!!

- o) Replace the 5/16UNC (C) bolts. Do not torque yet – just make it snug.
- p) Install the oil fittings (not included) as per service manual.
- q) Install on the heads as per service manual. If you're using SNS billet heads, you need to procure the mounting hardware as per RECOMMENDED HARDWARE LIST below.
- r) Torque the screws (C) to 12-15 ft/lbs.
- s) Re-install all externals (oil lines and pushrods as per service manual, also any bracketry (if applicable). Make sure to use appropriate to your application pushrod tube seals (not included).
- t) Once everything has been assembled and properly adjusted, rotate the crankshaft by hand checking for any possible interference and/or obstacle. If you observe ANY resistance, stop immediately and investigate the cause. Failing to do so may cause an extensive engine damage and will not be covered by warranty.

*****While re-installing the assembled components into the frame, check for potential interference. We have incorporated clearances into the design (especially Rear Box), but due to the variety of frames being used (OEM or Custom) the installer may be required to perform some minor modifications as needed. Remove the least amount of material possible and only from the interfering area.*****

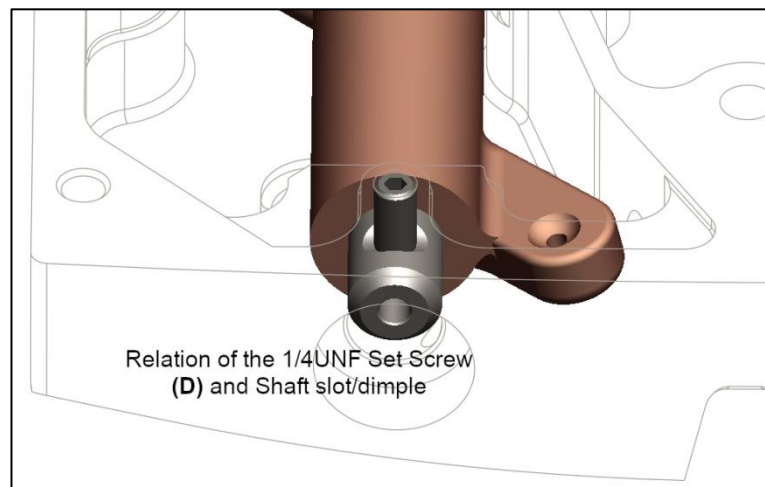
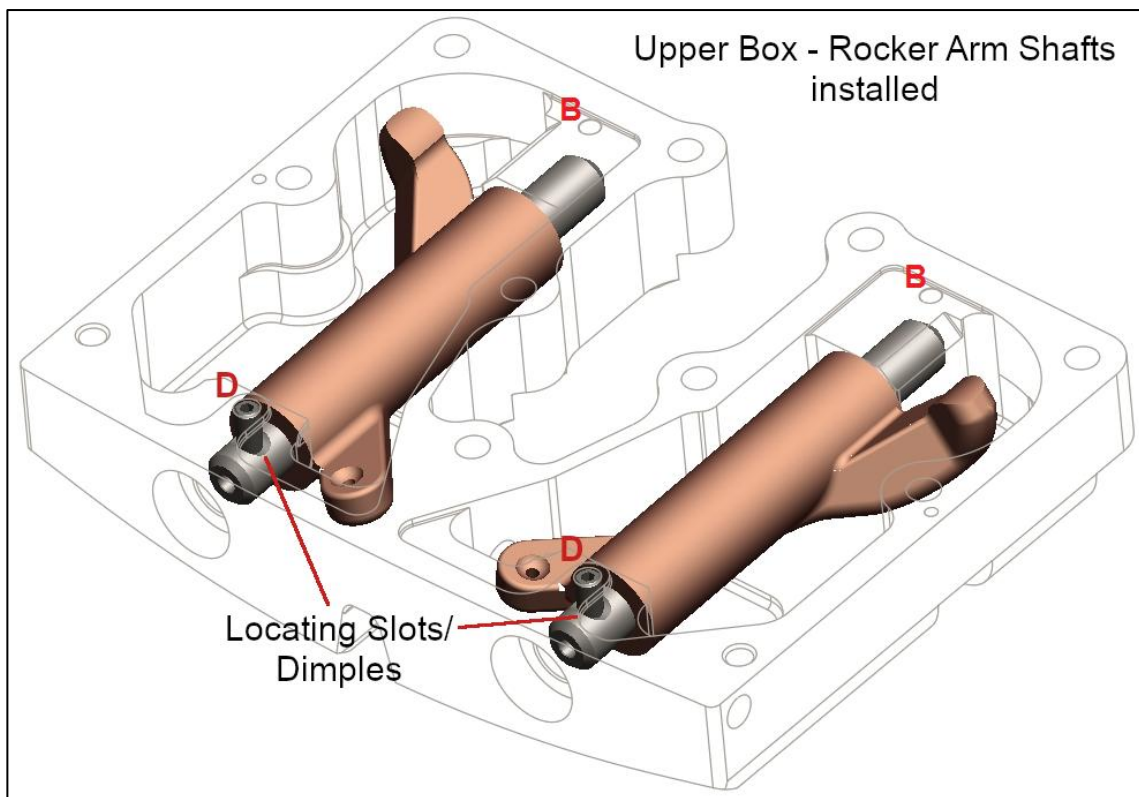

**** Some Rocker Arms require careful grinding / buffing of the forging "overhang" in order to clear the radii, as indicated here:**

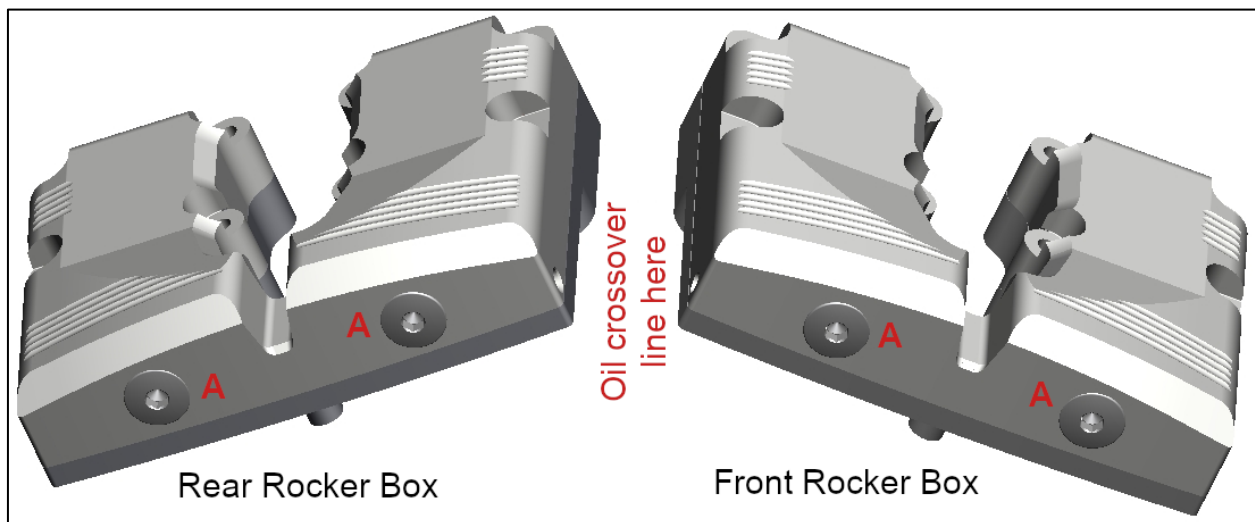
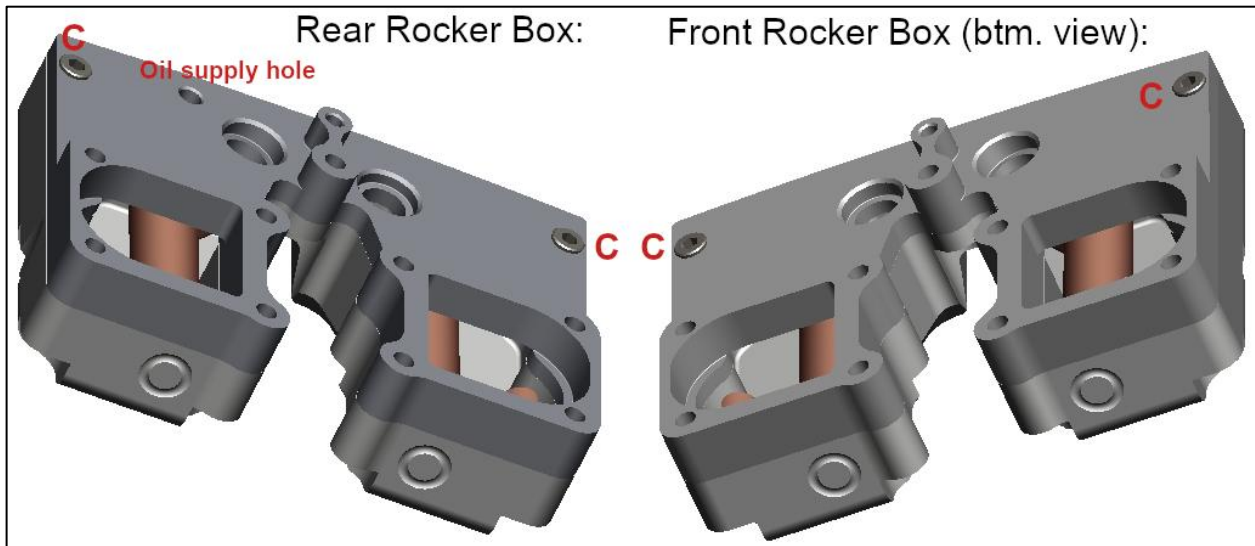
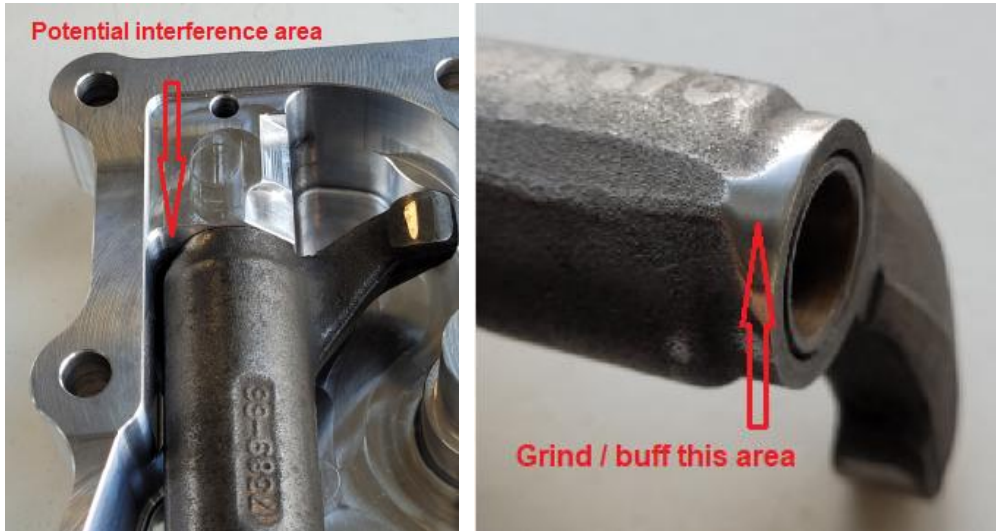

OPTIONAL FOR PURCHASE (available on our website):

- ✓ Rocker Box Fastener Kit (SH_FSTNR_001)
- ✓ Rocker Box oring kit (4 + 4)
- ✓ End Cap set (4)

RECOMMENDED HARDWARE LIST (to be procured locally by the purchaser):

Qty. 2 Rocker Box gaskets