

READ ME FIRST!!!



SPEED AND SCIENCE Billet Aluminum (Single or Dual Carburetor) Cylinder Heads for 1966-1984 Harley Davidson® “SHOVELHEAD” engines

8190 River Road
Delta, BC V4G 1B5, CANADA
T: 778-727-0866
www.speedandscience.com
sales@speedandscience.com

<i>Revision:</i>	<i>Description:</i>	<i>DATE:</i>
03	<i>Descriptions / Procedures clarified</i>	<i>Nov 21 2019</i>
04	<i>Redundant info removed</i>	<i>Jan 20 2022</i>

DISCLAIMER:

SPEED AND SCIENCE (SNS) parts are designed and intended for closed course applications only. Our products must be installed by a mechanic experienced in American V-Twin engines and used by an experienced rider. Installation of SNS parts may affect or even void any other warranties if such apply to your motorcycle. Additionally, such installation may violate some federal, provincial, state and local laws, rules and ordinances. Always check federal, provincial, state and local laws prior to modifying your motorcycle. It is the sole and exclusive responsibility of the user to determine whether the product is correct for his/her use. The user shall assume all legal risks, liabilities, duties and obligations associated therewith.

Trademark Disclaimer: *The words Harley-Davidson®, H-D®, Sportster®, Evolution® TwinCam® and all OEM part numbers and model designations are registered trademarks of H-D Michigan, LLC, and are used for reference only. Speed And Science is not associated with Harley-Davidson, Inc.*

*****Not EPA Compliant, please check with your local Motor Vehicle Office for rules and regulations*****

INSTALLATION AND OPERATION SAFETY:

It is your responsibility to read and follow these instructions thoroughly and carefully prior to attempting any work on your motorcycle. Make sure you understand all procedures completely. Contact SNS with any questions you may have regarding an installation and/or operation of any SNS product. Please make safety your priority.

- *Motorcycle fuel is extremely flammable and explosive media, also toxic when breathed/ingested. Work only in well ventilated room equipped with appropriate fire extinguishing gear. Avoid any open flames or sparks, do not smoke.*
- *Exhaust fumes are toxic and must not be breathed. Run your motorcycle in a well ventilated area; also never stay in the way of the exhaust fumes.*
- *Motorcycle engine and certain accessories do get very hot after even a very short run. Always allow those to cool down before attempting any work.*
- *Always disconnect the motorcycle battery prior to attempting any work. Secure the battery terminals and cables to prevent any accidental re-connect and/or short-circuit.*
- *Consult an appropriate service manual[s] for other procedures that may be needed in order to facilitate an installation of the SNS part[s].*
- *Never work on, or operate your motorcycle while under influence of alcohol or drugs. Fatigue will affect your proper judgement ability also. Please keep yourself and others safe.*
- *Always check federal, provincial, state and local laws prior to modifying your motorcycle.*

WARRANTY:

- *All SNS parts are guaranteed to the original purchaser to be free of manufacturing defects in materials and workmanship for a period of 12 (twelve) months from the date of purchase.*
- *SNS must be notified immediately about any of our products that do not conform to the above. After a case review, an RMA number will be issued to the purchaser and the product[s] must be returned pre-paid to us within the 12 month warranty period or 10 business days thereafter and will be replaced or repaired at SNS's option.*
- *The returning parts must be packaged properly as to prevent any shipping damage.*
- *The shipment must include a copy of the original purchase receipt, Invoice, etc., also a detailed note outlining the nature of the problem.*
- *Upon positive case review, a repair, replacement or refund will be granted.*
- *The purchaser is solely responsible for proper installation of any SNS product, using proper tools and techniques as per commonly used shop procedures and manuals.*
- *SNS shall not be responsible for any part defects being result of improper installation, improper/lack of maintenance, improper use and operation, or any other abnormal misuse or mistreatment of said part.*
- *SNS shall be not liable for any consequential or incidental damages resulting from the failure of a SNS part, the breach of any warranties (written or implied), the failure to deliver, etc.*

INSTALLATION GUIDANCE AND RECOMMENDATIONS:

*** * * WARNING!!! * * ***

- ***Anytime during assembly and/or while checking for clearances, under NO CIRCUMSTANCES the engine should be forced to rotate if ANY RESISTANCE is observed. Doing so, or failing to provide correct clearances may cause an engine damage and will not be covered by warranty.***

1. SNS Shovelhead Headset has been designed to fit all 1966-1984 Harley Davidson "Shovelhead" models with stock bores (3-7/16" up to +.090" or 3-1/2" up to +.030") and internal oil drains. An utmost care has been exercised to ensure a direct fit and function, however due to the large variety of models manufactured and/or extensive customization afterwards, the installer may be required to perform some minor modifications as needed.
2. Speed And Science Rocker Boxes are recommended for superior fit and function, but the heads can use stock rocker boxes as well. Due to the casting variations, some OEM boxes may have thicker walls that could interfere with the top valve spring retainer (top hat). In that case, a careful material removal from the inside of the rocker box will be needed to obtain a clearance of min. .060". Remove the least amount of material possible and only from the interfering area.
3. The heads design requires the head gasket to be min. .035" thick in installed (crushed) condition to provide an appropriate (.001" to .005") clearance to the head's counterbore.
4. The combustion chamber shape requires using OEM shape piston. That provides the "squish" action necessary to create an extra turbulence during compression stroke. Those gaps (distance between the top of the piston and bottom of the combustion chamber) should be never less than .025" but no more than .035". Certain aftermarket high-dome pistons will interfere with the "squish band" areas of the head and cause severe damage, so be sure to use correct components and carefully measure everything. Using modeling clay is the most common method to verify such gaps. Any deviation from the recommended value may be rectified by either using thicker cylinder base gaskets (gaps smaller than .025") or by removing small amount of material from the cylinder base (gaps larger than .035").
5. Installation of Rocker Boxes should be done as per service manual. OEM shape gaskets must be used, but please note that SNS heads do not come with mounting studs. See the recommended Hardware List below.

6. **Dual Carb Only:** Intake Manifolds are very easy to assemble while the heads are still on the bench. Please note, the intakes are different for each (front/rear) head and will fit only one way (see pictures below). Prior to their assembly, the supplied seals (thin orings) must be installed. The seals are purposely slightly oversized and need to be “worked around” with your fingers into each counterbore on the intake port face (heads), until fully seated inside. Each manifold then need to be carefully aligned with the heads and the provided bolts gradually drawn tight, starting with the upper SHCS-type bolt (use Ball-end Allen key for that one). Bottom bolts are of the HEX Head type for easy access with a flat wrench. Afterwards inspect the flange↔head joints for full, metal-to-metal contact all around. Assembled heads should be installed on top of cylinders as per service manual.

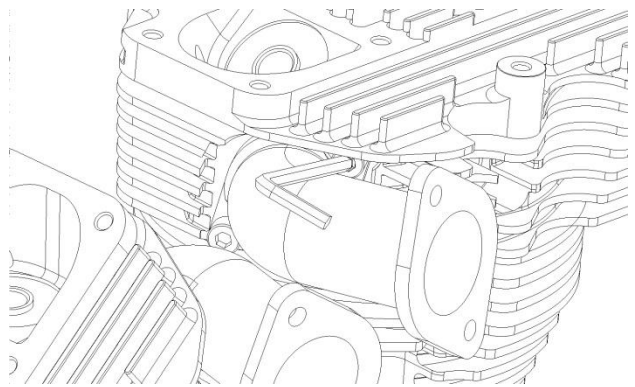
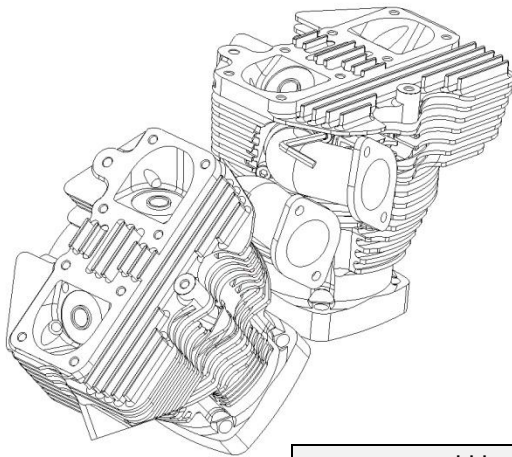

*****SHOVELHEAD head pictured for reference only*****

For an easy access, Double (shown) and Single Intake Manifolds require SHCS bolts on the top (use ball-end Allen key) and HEX bolts on the bottom (use flat wrench).

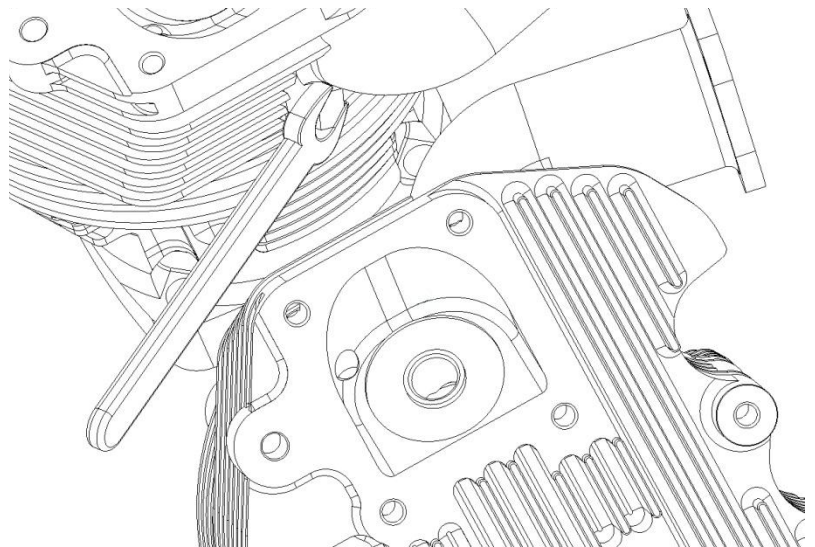
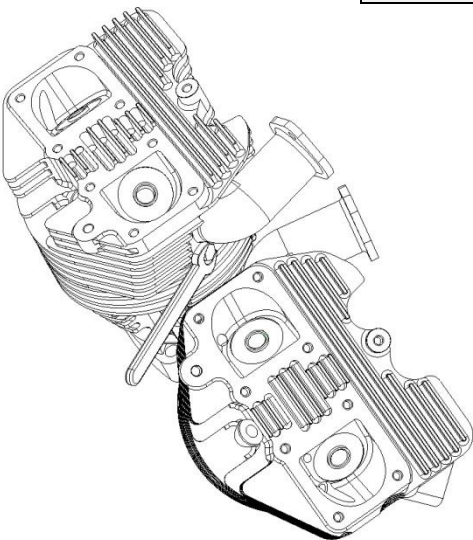

7. **Single Carb Only:** the Y-Split intake manifold needs to be attached to an engine after both heads are in place. Minute adjustment of the head positions (clocking) is recommended before

final fastening the head bolts. In order to do that, remove the manifold seals/clamping flanges. Use the exposed openings of the manifold to “clock” the heads for best fit that provides small, uniform gaps between the manifold and both intake ports. Remove and put aside the manifold. Fasten the heads as per service manual.

8. Single Carb Only: make sure both bottom manifold HEX bolts/washers are screwed in (few threads only) into each head. Remove both top SHCS bolts/washers and put them aside. Install the conical seals (cone end forward) into the mounting flanges. Slide the flanges and seals onto the manifold’s open ends until they’re flush with manifold’s openings. Visually line up the slots in both flanges with the pre-installed bolts. Carefully slide the subassembly into position between the heads while fine-adjusting the flanges to make sure that their slots go under corresponding HEX bolts/washers. Once in place, add the top SHCS bolts and gradually draw all four bolts tight. Keep moving the intake’s center section slightly up and down while torquing to make sure the best fit is achieved. Afterwards inspect the flange↔head joints for full, metal-to-metal contact all around.
9. The engine top mounting studs (see optional SH_FSTNR_001 kit below) needs to be installed as per service manual into the top 7/16-14 threaded holes, blue Loctite recommended
10. The exhaust outlet has been designed to fit either single-bolt OEM headers or the common, three-bolt aftermarket flanges. The exhaust port ID has been designed with a minimum clearance over the stock exhaust pipe stub – in some cases (e.g. deformed header) a careful grinding of the stub’s OD may be required.
11. Heads accept M12x1.25, ¾” reach spark plugs (please see Hardware List below).
12. Due to the advanced combustion chamber shape and fast ports, the engine requires less ignition advance compare to OEM. A good starting point for setting the Ignition timing is 5deg/26deg (idle/full advance) before TDC. An electronic, programmable ignition module will allow for the best advancement curve for your build, riding style, area/elevation, available gasoline, etc. It’s up to your engine tuner to test and determine best timing.
13. Similarly, tuning the engine for the best mixture ratio needs to be done by an experienced mechanic / dyno operator. ***Please note that in any case an appropriately strong support bracketry for the carburetor[s] must be fabricated by the builder – the provided intake manifolds (Y-split or elbows) are NOT designed to withstand the stress induced by the weight of the carb hanging solely off of it.
14. The break-in procedure, bolt re-torquing (heat-cycles) sequence, etc. must be done as per service manual.

OPTIONAL FOR PURCHASE (available on our website):

- ✓ VALVETRAIN HARDWARE KIT (SH_VLVTRN_001)
- ✓ Rocker Box Fastener Kit
- ✓ Intake Manifold oring kit (double carb system)
- ✓ Intake Manifold cone seals (single carb system)

RECOMMENDED HARDWARE LIST (to be procured locally by the purchaser):

- | | |
|--------|---|
| Qty. 2 | 12MM, ¾” reach Spark Plugs, e.g. NGK DCPR7E |
| Qty. 1 | MLS Head Gasket Set |
| Qty. 2 | Exhaust gaskets |
| Qty. 1 | Rocker Box Gasket set |