

**\*\*\*BREAKING NEWS\*\*\***

The screenshot above represents our latest and greatest coming down from the design department: billet aluminum headset for the H-D EVOLUTION engines.  
So, what's hiding behind the pretty picture? Quite a bit, actually. We've completely redesigned the combustion chamber and ports (self-explanatory). More cooling area (especially on top), so all the extra power can be easily handled. No need to machine your heads for tall camshafts anymore, that's already taken care of. 7MM valve stems for less flow obstruction, hi-tensile beehive springs. And the list goes on.

---

Pending the final tests, the first release (for the 80CUI EVO engines) should hit the market later this Summer. Larger displacements will follow.

---

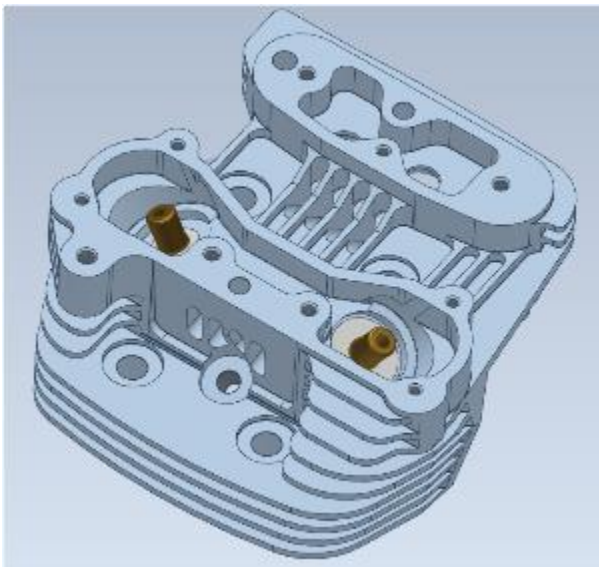

---

Projected headset price (loaded and locked) is US\$1,780. First 25 pre-orders will qualify for an unreal 25% discount - please contact us to reserve yours!

---

*Ride Safe and Ride Often,  
Speed And Science Team*

