

READ ME FIRST!!!



EFI Conversion Kit for the SPEED AND SCIENCE version of 1966-84 Harley Davidson® “SHOVELHEAD” or “PANSHOVEL” engines

8190 River Road
Delta, BC V4G 1B5, CANADA
T: 778-727-0866
www.speedandscience.com
sales@speedandscience.com

Revision:	Description:	DATE:
01	HALL Sensor wiring info added.	Sep 11 2024

DISCLAIMER:

SPEED AND SCIENCE (SNS) parts are designed and intended for closed course applications only. Our products must be installed by a mechanic experienced in American V-Twin engines and used by an experienced rider. Installation of SNS parts may affect or even void any other warranties if such apply to your motorcycle. Additionally, such installation may violate some federal, provincial, state and local laws, rules and ordinances. Always check federal, provincial, state and local laws prior to modifying your motorcycle. It is the sole and exclusive responsibility of the user to determine whether the product is correct for his/her use. The user shall assume all legal risks, liabilities, duties and obligations associated therewith.

Trademark Disclaimer: *The words Harley-Davidson®, H-D®, Sportster®, Evolution® TwinCam® and all OEM part numbers and model designations are registered trademarks of H-D Michigan, LLC, and are used for reference only. Speed And Science is not associated with Harley-Davidson, Inc.*

*****Not EPA Compliant, please check with your local Motor Vehicle Office for rules and regulations*****

INSTALLATION AND OPERATION SAFETY:

It is your responsibility to read and follow these instructions thoroughly and carefully prior to attempting any work on your motorcycle. Make sure you understand all procedures completely. Contact SNS with any questions you may have regarding an installation and/or operation of any SNS product. Please make safety your priority.

- *Motorcycle fuel is extremely flammable and explosive media, also toxic when breathed/ingested. Work only in well ventilated room equipped with appropriate fire extinguishing gear. Avoid any open flames or sparks, do not smoke.*

- Exhaust fumes are toxic and must not be breathed. Run your motorcycle in a well ventilated area; also never stay in the way of the exhaust fumes.
- Motorcycle engine and certain accessories do get very hot after even a very short run. Always allow those to cool down before attempting any work.
- Always disconnect the motorcycle battery prior to attempting any work. Secure the battery terminals and cables to prevent any accidental re-connect and/or short-circuit.
- Consult an appropriate service manual[s] for other procedures that may be needed in order to facilitate an installation of the SNS part[s].
- Never work on, or operate your motorcycle while under influence of alcohol or drugs. Fatigue will affect your proper judgement ability also. Please keep yourself and others safe.
- Always check federal, provincial, state and local laws prior to modifying your motorcycle.

WARRANTY:

- All SNS parts are guaranteed to the original purchaser to be free of manufacturing defects in materials and workmanship for a period of 12 (twelve) months from the date of purchase.
- SNS must be notified immediately about any of our products that do not conform to the above. After a case review, an RMA number will be issued to the purchaser and the product[s] must be returned pre-paid to us within the 12 month warranty period or 10 business days thereafter and will be replaced or repaired at SNS's option.
- The returning parts must be packaged properly as to prevent any shipping damage.
- The shipment must include a copy of the original purchase receipt, Invoice, etc., also a detailed note outlining the nature of the problem.
- Upon positive case review, a repair, replacement or refund will be granted.
- The purchaser is solely responsible for proper installation of any SNS product, using proper tools and techniques as per commonly used shop procedures and manuals.
- SNS shall not be responsible for any part defects being result of improper installation, improper/lack of maintenance, improper use and operation, or any other abnormal misuse or mistreatment of said part.
- SNS shall be not liable for any consequential or incidental damages resulting from the failure of a SNS part, the breach of any warranties (written or implied), the failure to deliver, etc.

INSTALLATION GUIDANCE AND RECOMMENDATIONS:

*** * * CRITICAL WARNING!!! * * ***

- **WARNING: during system testing / operation all fuel lines will be under high pressure. Any leak could be extremely dangerous. Only EFI-rated fuel lines, connectors, etc. (rated to min. 250PSI) must be used. Utmost care is required! Keep the fire extinguisher handy at all times!!**
- **Anytime during assembly and/or while checking for clearances, under NO CIRCUMSTANCES the engine should be forced to rotate if ANY RESISTANCE is observed. Doing so, or failing to provide correct clearances may cause an engine damage and will not be covered by warranty.**

1. SNS EFI Kit provides an unmatched performance and tuneability over the traditional, carbureted fuel delivery system. It is NOT plug-and-play conversion - the installation process requires significant knowledge and experience in both mechanical and electrical systems.
2. This system works ONLY with the Speed And Science headsets (Shovelhead or PanShovel). Previously purchased headsets can be sent back to us for required modifications. NOTE: these modifications do not affect your current carburetion setup and can be used with either fuel delivery system.
3. This system requires electric starter (no kick-only engines).
4. When operational, this system will draw up to 20 amps, thus it requires 32A alternator in good condition. In order to provide enough current to run the system and charge the battery, headlight / taillight needs to be switched to LED's.
5. Fuel pump must be powered via an automotive relay. If an external 12V in-line fuel pump is to be used, please make sure that its required current does not exceed 6A. Best, if a dedicated motorcycle fuel tank with a built-in EFI pump/filter is used. Either type should be able to produce about 45PSI (regulated) running pressure.
6. The ECU / peripherals installation must be done in accordance with the MS manual. Proper 12V / 5V / Ground cable routing is absolutely critical. Do not take any shortcuts or use inferior components!
7. OPTIONAL (actual application dependent): for easier installation / cable routing, the MICROSQIRT harness should have unused pins/wires removed from the AMPSEAL plug. Please refer to the MS manual or the picture on pg. 6. **Please note: removing wires from the AMPSEAL connector will make it non-sealed.
8. Your existing ignition system (mechanical or electronic) needs to be replaced with the supplied 24-1 Trigger Wheel along with the HALL Sensor Mounting Plate. Please make sure that the Trigger Wheel locating feature fully engages the camshaft notch. The airgap between the Trigger Wheel (OD) and the HALL sensor should be about 1MM. The round openings in the Mounting plate allow for that - use an appropriate thickness wire to verify. No physical contact with the rotating assembly is allowed.
9. The provided HALL sensor requires pull-up voltage. For that reason, the AMP'd version of the MicroSquirt comes with an internal set of Dip switches. Enabling SW3 supplies the pull-up voltage to the HALL sensor. For non-AMP'd units, an external pull-up 1k resistor needs to be soldered in (as per the MS manual):

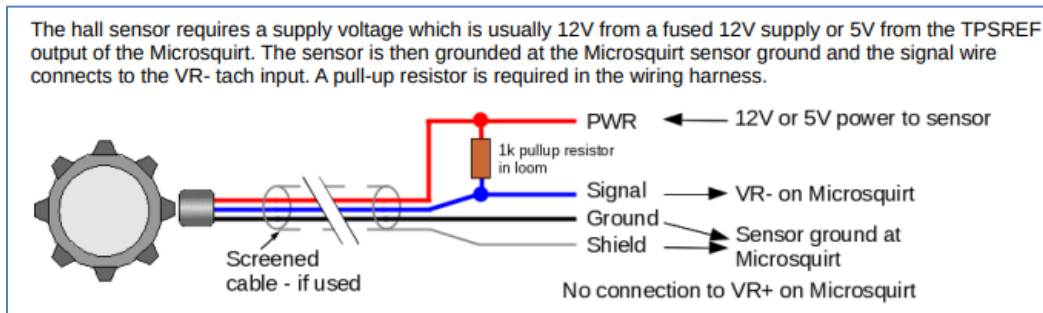

10. We supply the HALL Assy. with a pre-made cable. It must be connected to MicroSquirt (via supplied DEUTSCH 3-pin connector) as follow:
 - BLACK wire → PIN# 33 (VR1-)
 - YELLOW wire → PIN# 18 (Sensor GND)
 - RED wire → PIN# 1 (+12V)
11. Upon completing the installation, everything MUST be double-checked, and any wiring mistake corrected. Due to the project complexity, a second set of eyes is highly recommended - it will make the initial startup much easier.
12. After making sure that everything has been wired up and connected properly, it's time to test individual components under power (DO NOT attempt to start the engine just yet!). **MegaSquirt Setting Up Manual (https://www.msextra.com/doc/pdf/Megasquirt3_Setting_Up-1.5.pdf) has an excellent, very detailed set of How-To instructions. Most of those are applicable to the MicroSquirt as well.

13. Install the TunerStudio software (downloadable from <http://www.EFIAnalytics.com>) on your laptop or PC. Load up the initial SNS_base_01.msq tune file provided with the kit. These base settings should allow (for the properly installed system) to fire up easily. The same software will allow you to fine-tune your engine later on.
14. Connect the system to the TunerStudio; follow the TS manual for the how-to's. Once the communication has been established, you can access the I/O test functions for fuel pump, injectors, ignition coils, etc. Please use those to make sure that everything works as it supposed to. ****Throughout the tests, ANY FUEL LEAKS are potentially lethal and must be fixed immediately!**
15. Once the above tests have been successfully completed, the next step is to verify the cam tach-in signal. Disable the fuel pump, injectors and coils. Make sure there's oil in the engine. Pull the spark plugs. Key-on the engine and open up the Tooth Logger on the TS. Crank the engine for a min. 10sec. After a short while you should see a similar pattern generating on the screen:

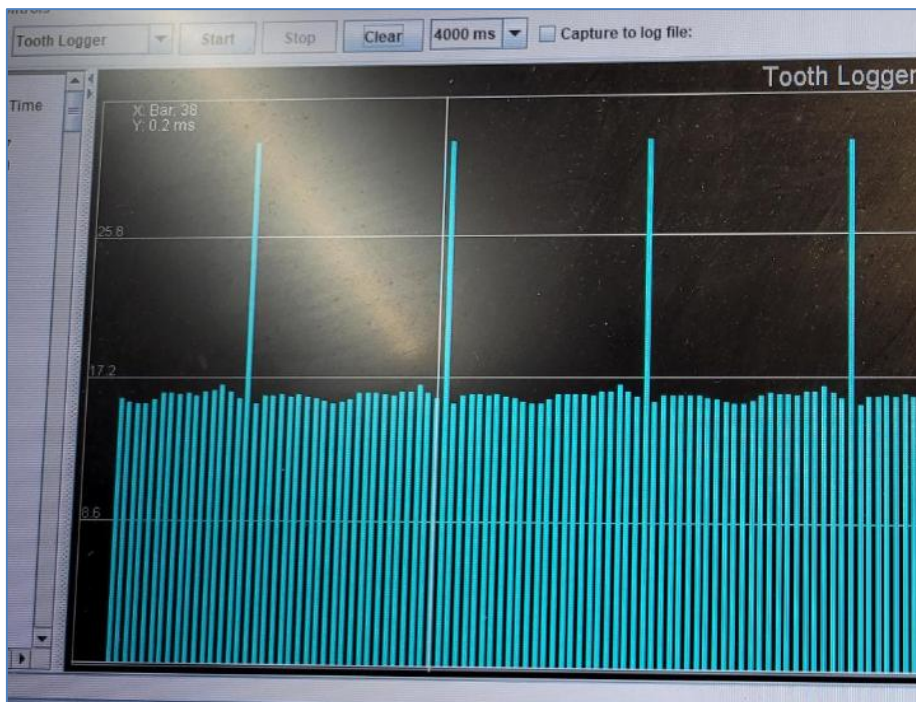

16. Once the above test has been successfully completed, the next step is to check the ignition timing (keep the spark plugs off). Install a timing wheel or mark the first 10, 9, 8, ..., 0 Degrees BTDC (front cylinder) at the crankshaft sprocket end. Enable the coils, and crank the engine while verifying the timing angle with the strobe light. It should read 6deg BTDC @ cranking RPM. This angle can be adjusted via TS (Tooth #1 Angle) setting.
17. Now that you've confirmed sensor inputs, coil / injector outputs and cranking timing, you are ready to start the engine. Double check the oil level. Enable the fuel pump, injectors and coils. Ensure that the battery is charged, spark plugs are fitted, plug leads are in place and all hoses are secure. Start a data log (Data Logging menu and select Start Logging). Now, hit the starter for a few seconds. It is common to need to give the engine a little throttle to keep it alive on the first start. If all sounds well, then keep the engine running and warm it up. If anything sounds / looks wrong - STOP and investigate. If things aren't working out, then most likely there's an issue with any of the previous steps. Please go back and double-check everything. If in doubt about anything, please step back and call us.

ADDITIONAL NOTES:

****All OEM HD sensors and other related hardware listed at the bottom of this document need to be purchased separately. SNS doesn't provide any of those.

****The break-in procedure, bolt re-torquing (heat-cycles) sequence, etc. must be done as per service manual.

RECOMMENDED HARDWARE LIST (to be procured locally by the purchaser):

- ✓ ECU: AMP'd MicroSquirt w. 30" harness (DIYAutoTune)
- ✓ USB to SERIAL adapter (DIYAutoTune)
- ✓ Fuel Injectors (Qty. 2, HD P/N 27709-06A, 275cc/hr)
- ✓ TPS (Throttle Position Sensor HD P/N 27569-06)
- ✓ IAT (Intake Air Temp. Sensor HD 27381-06)
- ✓ Engine Temp. Sensor (HD 32446-99 or MC-TS1 w. ½-20UNF thread)
- ✓ MAP (Manifold Pressure Sensor HD 32417-10)
- ✓ Idle Stepper Motor (HD27568-06)
- ✓ Fuel Rail Service Kit (HD27651-06)
- ✓ Logic Ignition Coils (Qty. 2, P/N AC DELCO BSC1251 or similar) w. pigtails and spark plug wires
- ✓ Wideband O2 Sensor w. Controller (14Point7 Spartan 3 Lite V2 or similar)
- ✓ MicroSquirt IAC Stepper Adapter (EFISource.com)
- ✓ 51MM Throttle Body (HPI Inc., P/N: HPI-51D6-16)
- ✓ Fuel tank w. built-in EFI fuel pump / filter (or stand-alone 45PSI Fuel Pump w. Pressure-regulated Fuel Filter)
- ✓ EFI-grade (braided) fuel hoses, assorted fittings
- ✓ Assorted connectors, 12V relays, wires, etc.

Parts Included in this Kit:

- ✓ EFI Intake Manifold w. mounting flanges / seals
- ✓ Fuel Rail w. mounting h/ware
- ✓ HALL sensor mounting plate w. Micro HALL Sensor / pigtail
- ✓ 24-1 Trigger Wheel w. mounting screw

MICROSQUIRT Harness (AMPSEAL connector) Pin designation:

Pin#	Name	Color	In/Out	Function	Max current
1	+12V In	Red	In	Main power feed	< 1A
2	CANH	Blue/Yellow	Comms	CAN communications	-
3	CANL	Blue/Red	Comms	CAN communications	-
4	VR2+	VR2	In	'Cam' tach in	-
5	SPAREADC2 (MAF)	Pink/Black	In	Spare analogue input	-
6	FLEX	Purple/White	In	Flex / spare input	-
7	FIDLE	Green	Out	Idle valve output	3A
8	FP (pump)	Purple	Out	Fuel pump relay output	3A
9	INJ 1	Thick Green	Out	Injector bank 1 output	5A
10	INJ 2	Thick Blue	Out	Injector bank 2 output	5A
11	SPK B (IGN2)	Thick White/Red	Out	Spark B logic output	0.02A
12	SPK A (IGN 1)	Thick White	Out	Spark A logic output	0.02A
13	RX	-	Comms	RS232 communications	-
14	TX	-	Comms	RS232 communications	-
15	BOOT LOAD	Purple/Black	In	Bootloader enable input	-
16	ALED	Yellow/Black	Out	Spare relay output	3A
17	WLED	Yellow/White	Out	Spare relay output	3A
18	Sensor Ground	-	GND	Not installed	-
19	Serial Ground	-	GND	Serial Ground	-
20	Sensor Ground	White/Black	GND	Sensor Ground	-
21	VR2-	VR2	In	'Cam' tach in	-
22	POWER GROUND	Thick Black	GND	POWER GROUND	-
23	POWER GROUND	Thick Black	GND	POWER GROUND	-
24	MAP	Green/Red	In	MAP sensor input	-
25	CLT	Yellow	In	CLT sensor input	-
26	MAT	Orange	In	MAT sensor input	-
27	TPS	Blue	In	TP Sensor input	-
28	TPS VREF (5V)	Gray	Out	5V supply for TPS	0.1A
29	SPAREADC	Orange/Green	In	Spare analogue input	-
30	OPTO+	Grey/Red	In	Coil negative tach in	-
31	OPTO-	Grey/Black	In	Coil negative tach in	-
32	VR1+	VR1	In	'Crank' tach in	-
33	VR1-	VR1	In	'Crank' tach in	-
34	O2	Pink	In	Oxygen/lambda sensor in	-
35	TACHO	Green/Yellow	Out	Tacho / rev counter out	0.3A